

# SUBMERSIBLE DEWATERING 12 VOLT DC PUMP

The FR12SPA1.5 is an excellent choice for remote dewatering on construction sites as well as agricultural, golf course, municipality or cemetery applications. DC power means it goes where you go to remove water and keep your projects on schedule. It is also great for emergency back up during a power failure.

**PUMPS** UP TO  
**42 GPM**  
159 LPM



FR12SPA1.5

## FR12SPA1.5 FEATURES

- Aluminum construction with cast iron impeller
- 1/3 HP, 12 Volt DC 30 amp motor
- 1½" NPT discharge
- Buna-N mechanical seal with carbon and ceramic faces
- Operates approximately 60 minutes on a fully charged 55 amp-hour battery
- Built-in carrying handle
- Integrated steel strainer
- Thermal overload protection
- 30' insulated power cord with integrated waterproof controller
- Fully assembled and ready for use
- Not for fuels



# FILL-RITE SUBMERSIBLE DEWATERING PUMP

## DIMENSIONS

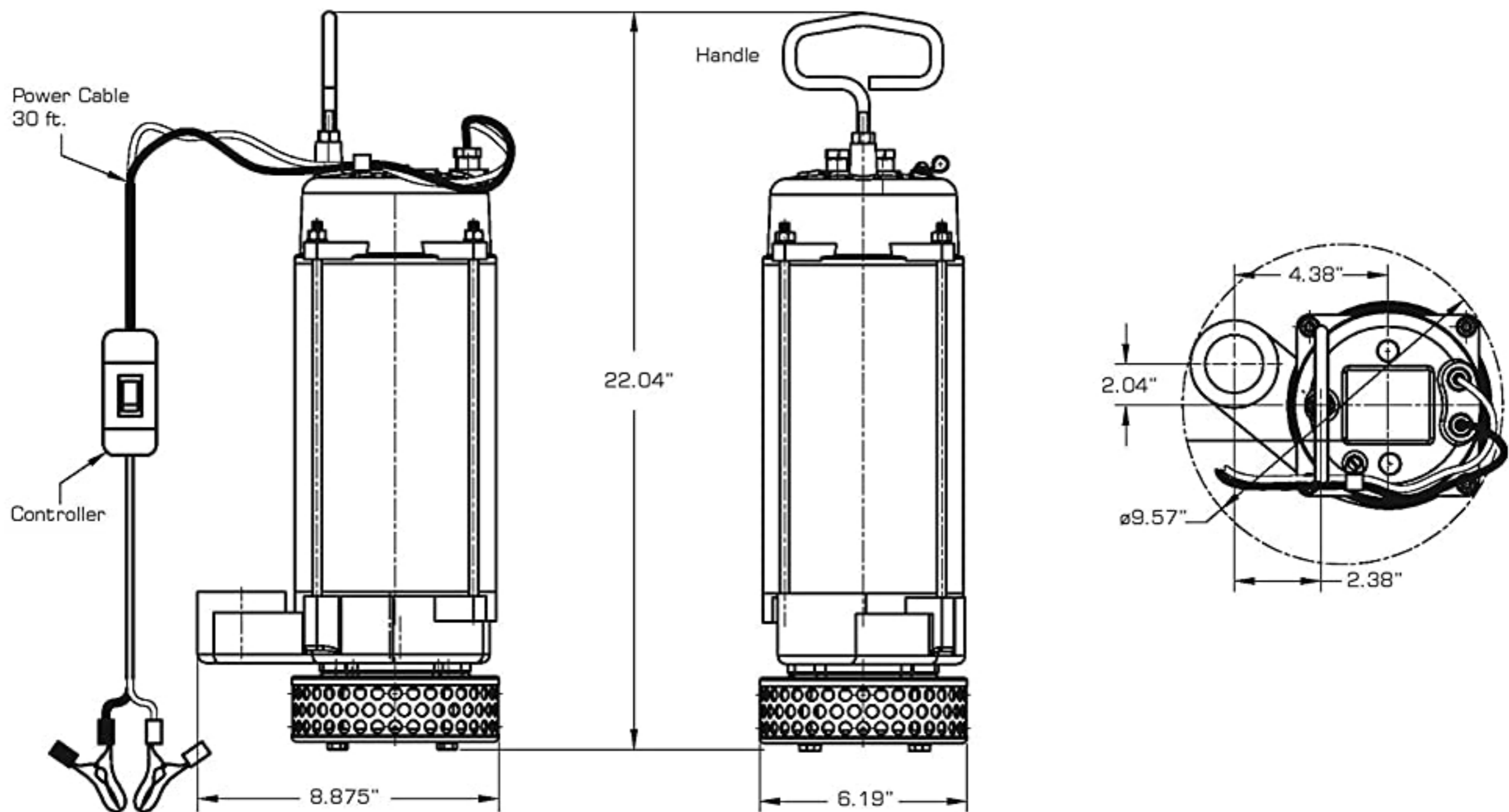

## PERFORMANCE

Flow Rate		Discharge Height	
42 GPM	157 LPM	5 Ft	1.5 M
34 GPM	129 LPM	10 Ft	3 M
25 GPM	95 LPM	15 Ft	4.5 M
21 GPM	81 LPM	20 Ft	6 M
0 GPM	0 LPM	25 Ft	7.6 M

\*altitude affects discharge height



Excellence at work. Excellence in life.

8825 Aviation Drive  
Fort Wayne, Indiana 46809  
P (800) 634-2695 or (260) 747-7524  
F (800) 866-4861



[FILLRITE.COM](http://FILLRITE.COM)