

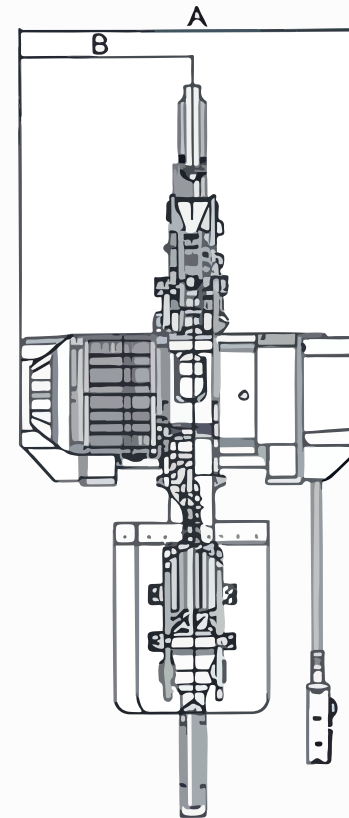

Aparéjos Eléctricos

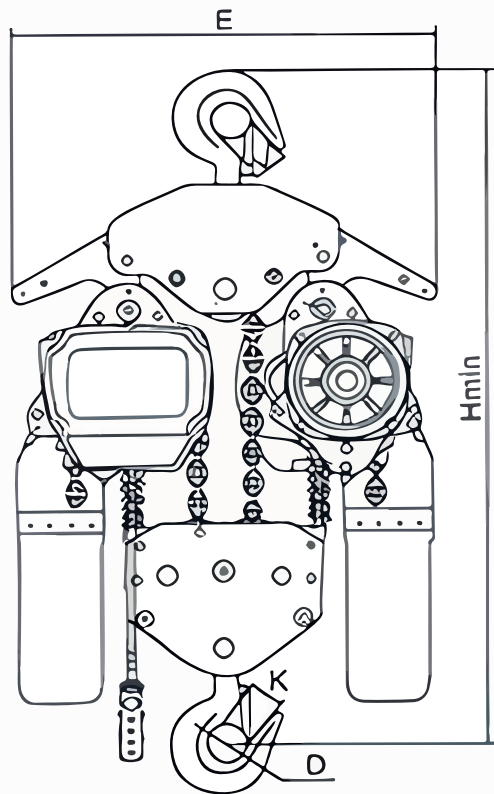
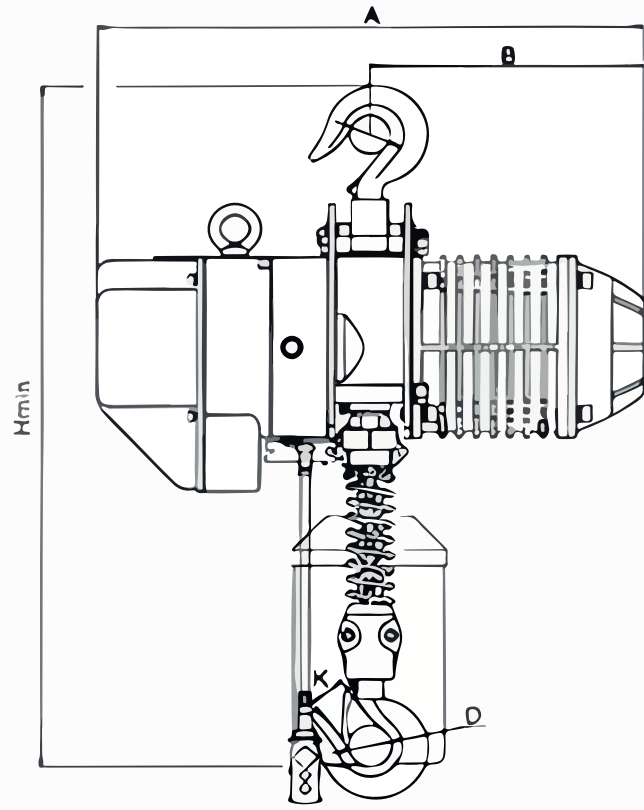
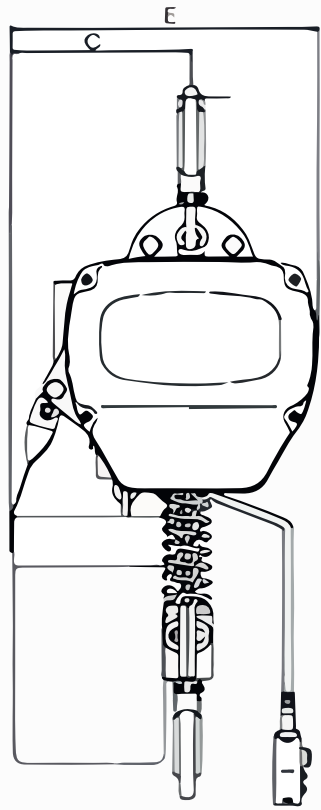

MODELO		DHS-1	DHS-2	DHS-3	DHS-5	DHS-10
CAPACIDAD DE ELEVACIÓN NOMINAL	(t)	1	2	3	5	10
ALTURA INICIAL ESTANDAR	(m)	3				
VELOCIDAD DE IMPULSO	(m/mim)	6,8	6,6	5,6	2,8	2,8
NUMERO DE LINEAS DE CADENA		1	1	1	2	4
TAMAÑO DE CADENA	(mm)	Ø 7,1 x 21	Ø 10 x 30	Ø 11,2 x 34	Ø 11,2 x 34	Ø Ø 11,2 x 34
POTENCIA DE MOTOR	(Kw)	1,5	3			
TENSION	(V)	220/380				
FRECUENCIA	(Hz)	50/60				
DIMENSIONES FISICAS (mm)	A	526	610	610	610	630
	B	263	300	300	300	315
	C	176	265	265	265	-
	D	Ø 42	Ø 50	Ø 60	Ø 60	Ø 85
	E	300	430	430	430	890
	K	34	40	50	48	80
	Hmin	610	750	815	1010	400
PESO NETO	(Kg)	61	115	115	145	300