

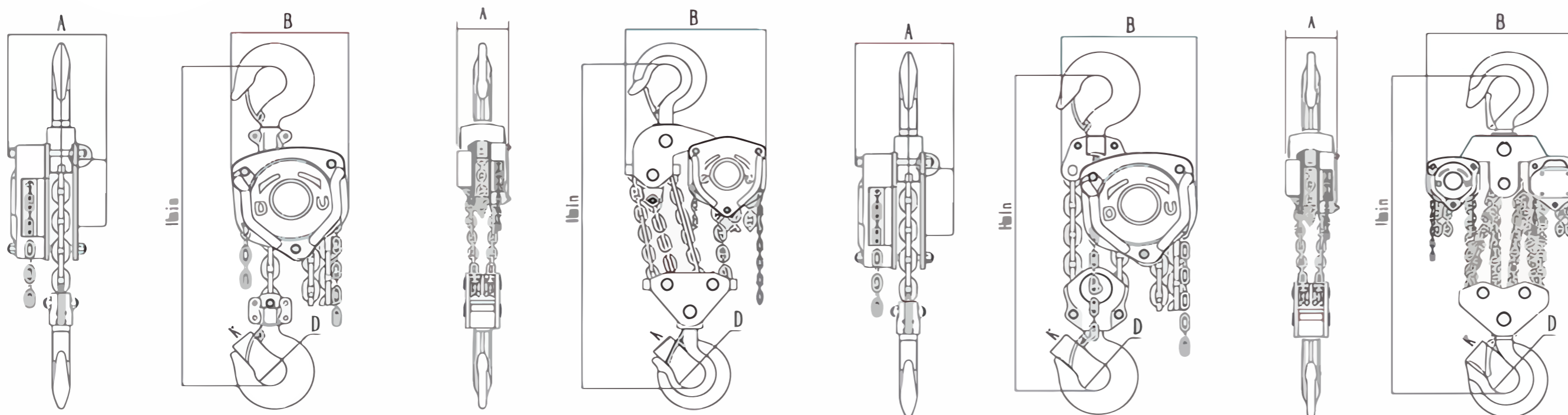

Aparéjos Manuales



MODELO		HSZ-1D	HSZ-2D	HSZ-3D	HSZ-5D	HSZ-10D
CAPACIDAD DE CARGA	(t)	1	2	3	5	10
ALTURA DE ELEVACION ESTANDAR	(m)	2,5	2,5	3	3	3
CARGA DE PRUEBA	(t)	1,5	3	4,5	6,25	12,5
FUERZA EN MANDO CON CARGA COMPLETA	(n)	301	314	343	383	392
NUMERO DE CADENAS DE ELEVACION		1	1	2	2	4
DIAMTRO DE CADENAS DE ELEVACION	(mm)	6	8	8	10	10
DIMENSIONES FISICAS (mm)	A	140	170	161	186	207
	B	158	187	210	253	398
	D	36	45	50	62	85
	K	28	36	38	48	64
	Hmin	317	420	465	635	700
PESO NETO	(Kg)	11	17,5	25,5	43	70
PESO A AÑADIR POR CADA METRO ADICIONAL	(Kg)	1,7	3,2	3,7	5,3	9,7

